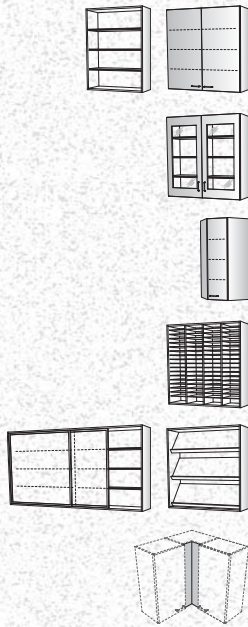

Table of Contents

HUTCH









Shelf	3
Display	4
Corner	5
Folder	6
Specialty	6
Installation Accessories	7
Design Details	8-9



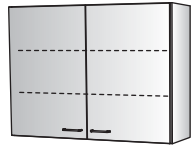

HUTCH

Commercial Cabinetry and Millwork

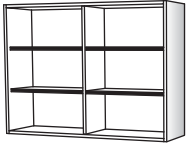
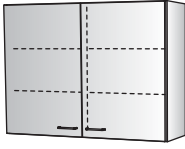
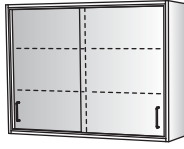

Hutch units are built for stacking on a countertop surface. Actual hutch heights are based on overall total height of elevation with the base and countertop combination used.

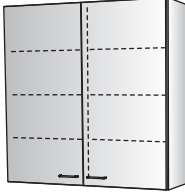
Shelf				
	<p>W: 12,15,18,21,24,27,30,33,36,39,42,45,48 H: 35,38,42,44,48,51,54,57,61 D: 14,18,21,24</p> <p>Adjustable Shelves</p>	<p>W: 12,15,18,21,24 H: 35,38,42,44,48,51,54,57,61 D: 14,18,21,24</p> <p>Right Hinge Door Adjustable Shelves</p>	<p>W: 12,15,18,21,24 H: 35,38,42,44,48,51,54,57,61 D: 14,18,21,24</p> <p>Left Hinge Door Adjustable Shelves</p>	<p>W: 24,27,30,33,36,39,42,45,48 H: 35,38,42,44,48,51,54,57,61 D: 14,18,21,24</p> <p>Doors Adjustable Shelves</p>
	22101	22120	22121	22129
<p>35H 38H 42H 44H</p>				
<p>48H 51H 54H 57H 61H</p>				

Shelf			
	<p>W: 39,42,45,48 H: 35,38,42,44,48,51,54,57,61 D: 14,18,21,24</p> <p>Center Divider Adjustable Shelves</p>	<p>W: 39,42,45,48 H: 35,38,42,44,48,51,54,57,61 D: 14,18,21,24</p> <p>Doors Center Divider Adjustable Shelves</p>	<p>W: 36,39,42,45,48 H: 35,38,42,44,48,51,54,57,61 D: 14,18,21,24</p> <p>Sliding Doors Center Divider Adjustable Shelves</p>
	22138	22181	22150
<p>35H 38H 42H 44H</p>			
<p>48H 51H 54H 57H 61H</p>			

HUTCH

Display



Hutch units are built for stacking on a countertop surface. Actual hutch heights are based on overall total height of elevation with the base and countertop combination used.



Display				
	<p>W: 15,18,21,24 H: 35,38,42,44,48,51,54,57,61 D: 14,18,21,24</p> <p>Right Hinge Display Door Adjustable Shelves</p>	<p>W: 15,18,21,24 H: 35,38,42,44,48,51,54,57,61 D: 14,18,21,24</p> <p>Left Hinge Display Door Adjustable Shelves</p>	<p>W: 30,36,42,48 H: 35,38,42,44,48,51,54,57,61 D: 14,18,21,24</p> <p>Display Doors Adjustable Shelves</p>	<p>W: 30,36,42,48 H: 35,38,42,44,48,51,54,57,61 D: 14,18,21,24</p> <p>Display Doors Center Divider Adjustable Shelves</p>
	22130	22131	22136	22182
<p>35H 38H 42H 44H</p>				
<p>48H 51H 54H 57H 61H</p>				

Display	
<p>W: 30,36,42,48 H: 35,38,42,44,48,51,54,57,61 D: 14,18,21,24</p> <p>Sliding Display Doors Center Divider Adjustable Shelves</p>	<p>W: 30,36,42,48 H: 35,38,42,44,48,51,54,57,61 D: 14,18,21,24</p> <p>Sliding Glass Doors Center Divider Adjustable Shelves</p>
22154	22158
<p>35H 38H 42H 44H</p>	
<p>48H 51H 54H 57H 61H</p>	

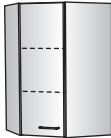
Hutch units are built for stacking on a countertop surface. Actual hutch heights are based on overall total height of elevation with the base and countertop combination used.

Corner – Diagonal	
<p>14" DEEP: W: 25 H: 35,38,42,44,48,51,54,57,61 D: 14</p> <p>18" DEEP: W: 28 H: 35,38,42,44,48,51,54,57,61 D: 18</p> <p>Right Hinge Door Fixed Shelves</p>	<p>14" DEEP: W: 25 H: 35,38,42,44,48,51,54,57,61 D: 14</p> <p>18" DEEP: W: 28 H: 35,38,42,44,48,51,54,57,61 D: 18</p> <p>Left Hinge Door Fixed Shelves</p>
22211	22212
<p>35H 38H 42H 44H</p> 	
<p>48H 51H 54H 57H 61H</p> 	

HUTCH

Folder / Specialty

Hutch units are built for stacking on a countertop surface. Actual hutch heights are based on overall total height of elevation with the base and countertop combination used.

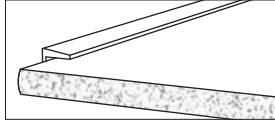

1/4"-thick folder shelves are held securely with translucent, low profile shelf supports. All edges unfinished. Front edge unfinished and shaped.



Folder

W: 21,24,30,36
H: 35,38,42,44,48,51,54,57,61
D: 14,18,21,24

1/4" Folder Shelves, Adjustable and Removable on 1 1/4" Centers
Compartments 2 1/4"H min.

22241



35H:
26 Compts.
38H:
28 Compts.
42H:
32 Compts.
44H:
34 Compts.
48H:
36 Compts.
51H:
38 Compts.
54H:
42 Compts.
57H:
44 Compts.
61H:
46 Compts.

W: 30,36,42,48
H: 35,38,42,44,48,51,54,57,61
D: 14,18,21,24

1/4" Folder Shelves, Adjustable and Removable on 1 1/4" Centers
Compartments 2 1/4"H min.

22242

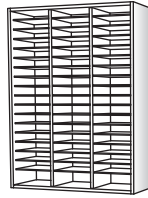

35H:
39 Compts.
38H:
42 Compts.
42H:
48 Compts.
44H:
51 Compts.
48H:
54 Compts.
51H:
57 Compts.
54H:
63 Compts.
57H:
66 Compts.
61H:
69 Compts.

W: 42,48
H: 35,38,42,44,48,51,54,57,61
D: 14,18,21,24

1/4" Folder Shelves, Adjustable and Removable on 1 1/4" Centers
Compartments 2 1/4"H min.

22243

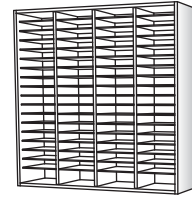

35H:
52 Compts.
38H:
56 Compts.
42H:
64 Compts.
44H:
68 Compts.
48H:
72 Compts.
51H:
76 Compts.
54H:
84 Compts.
57H:
88 Compts.
61H:
92 Compts.

Specialty

Magazine Shelf

W: 24,27,30,33,36,39,42,45,48
H: 48,51,54,57,61
D: 14,18,21,24

3 Magazine Shelves

22165

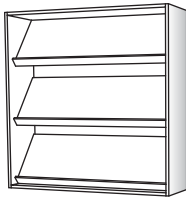

48H
51H
54H
57H
61H

Instructor White Board

W: 72,96
H: 48
D: 14,18,21,24

2 Sliding White Boards
2 Tracks
Center Divider
Adjustable Shelves

22300

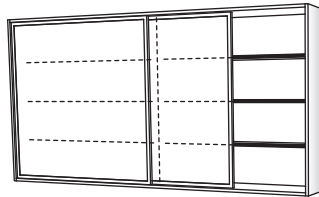



48H

W: 96
H: 48
D: 14,18,21,24

4 Sliding White Boards
4 Tracks
Center Divider
Adjustable Shelves

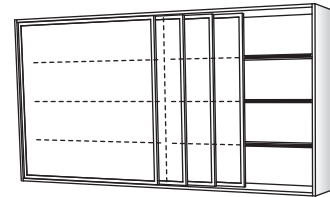
22302

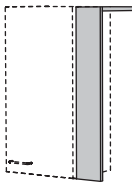
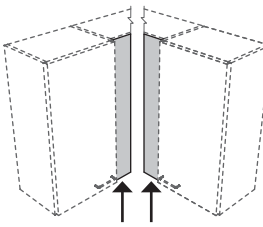
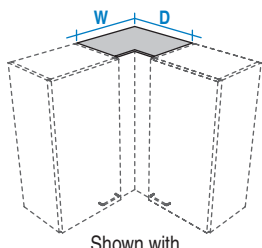

Soffit Trim	Vertical Scribe	Front Filler	Corner Filler	Top Corner Closure
<p>W: 96 H: 00 D: 03</p> <p>Field Trim to Fit Actual Thickness=$\frac{3}{4}$" Actual Depth=3" Edgebanding: One Long Edge in Casebody Trim Color and 0.5mm Thickness</p>	<p>W: 00 H: 35,38,42,44,48, 51,54,57,61 D: 14,18,21,24</p> <p>Field Trim to Fit Actual Thickness=$\frac{3}{4}$" Actual Depth=3" Edgebanding: One Long Edge in Casebody Trim Color and 0.5mm Thickness</p>	<p>W: 02,03,06,09,12 H: 35,38,42,44,48, 51,54,57,61 D: 14,18,21,24</p> <p>Field Trim to Fit Includes Top Closure Panel Edgebanding: Two Short Edges in Casebody Trim Color and .05mm Thickness</p>	<p>W: 02,03,06,09,12 H: 35,38,42,44,48,51,54,57,61 D: 14,18,21,24</p> <p>Field Trim to Fit Depths (D) Listed are Depths of Cabinets to which Filler is Attached Edgebanding: Two Short Edges in Casebody Trim Color and 0.5mm Thickness</p>	<p>W: 14,16,18,20,21,23,24,26 H: 00 D: 14,16,18,20,21,23,24,26</p> <p>Field Trim to Fit Edgebanding: None</p>
15801	15802	22803	22805	22809
			 Left Hand Right Hand Shown with 22809 Top Corner Closure	 Shown with 22805 Corner Filler

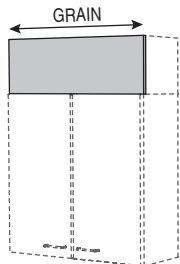
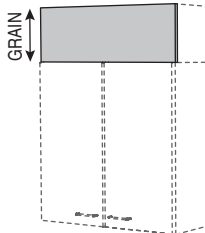
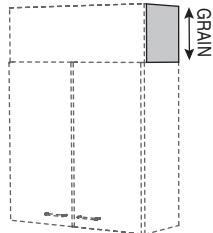
Horizontal Grain Soffit Fascia	Vertical Grain Soffit Fascia	End Soffit Closure
<p>W: 36,48,60,72,84,96 H: 12,18,24 D: 00</p> <p>Field Trim to Fit Edgebanding: One Long and Two Short Edges in Casebody Trim Color and 0.5mm Thickness</p>	<p>W: 12,15,18,21,24,27,30,33,36,39,42,45,48 H: 12,18,24 D: 00</p> <p>Field Trim to Fit Edgebanding: One Short and Two Long Edges in Casebody Trim Color and 0.5mm Thickness</p>	<p>W: 00 H: 12,18,24 D: 14,18,21,24</p> <p>Field Trim to Fit Edgebanding: All Edges in Casebody Trim Color and 0.5mm Thickness</p>
15822	15823	15820
 Shown with 15820 End Soffit Closure	 Shown with 15820 End Soffit Closure	 Shown with 15822/15823 Soffit Fascia

HUTCH / BASE ASSEMBLIES

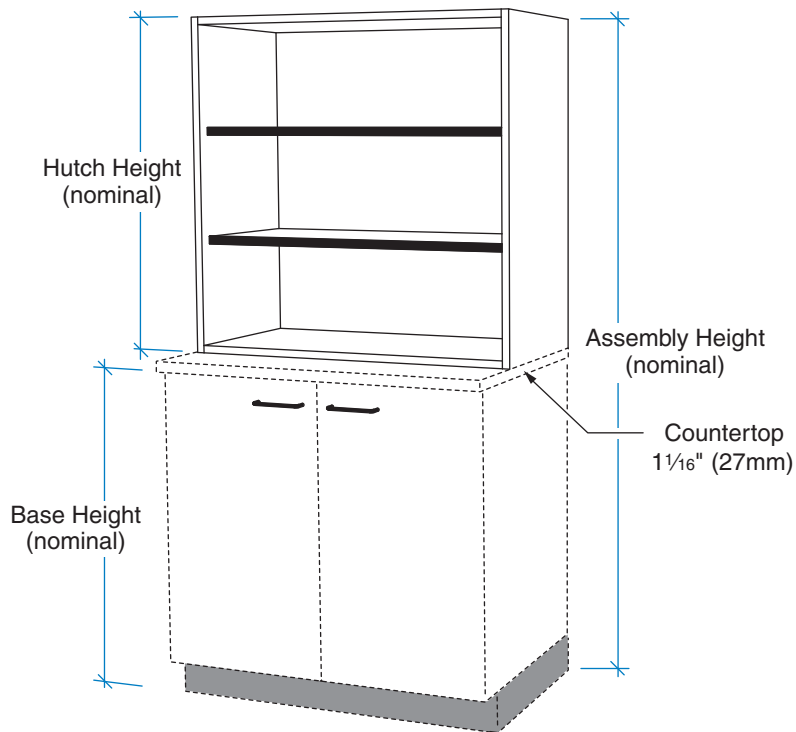

Hutch design is for stacking on base unit with countertop thickness of 1 1/16" (27mm). Actual hutch heights are provided based on overall total height of elevation with the base and special thickness countertop combination used.

Assembly Height* (nominal)	Assembly Height* (actual)		Base Height (nominal)	Hutch Height (nominal)	With 1 1/16" top (27mm)	
	inches	mm			Hutch Height (actual)	inches
72	71 9/16	1817	35	35	35 1/2	901
72	71 9/16	1817	32	38	38	965
72	71 9/16	1817	29	42	41 3/4	1061
78	77 13/16	1977	41	35	35 1/2	901
78	77 13/16	1977	35	42	41 3/4	1061
78	77 13/16	1977	32	44	44 5/16	1125
78	77 13/16	1977	29	48	48 1/16	1221
84	84 1/8	2137	41	42	41 3/4	1061
84	84 1/8	2137	35	48	48 1/16	1221
84	84 1/8	2137	32	51	50 9/16	1285
84	84 1/8	2137	29	54	54 3/8	1381
90	90 7/16	2297	41	48	48 1/16	1221
90	90 7/16	2297	35	54	54 3/8	1381
90	90 7/16	2297	32	57	56 7/8	1445
90	90 7/16	2297	29	61	60 11/16	1541

* Assembly heights based on using 1 1/16" (27mm) top.

Design Details

Typical hutch combinations are shown as the base and hutch unit nominal heights with a 1/16" (27mm) countertop thickness.

72 HIGH ASSEMBLY

Actual Height
71 1/16" (1817mm)

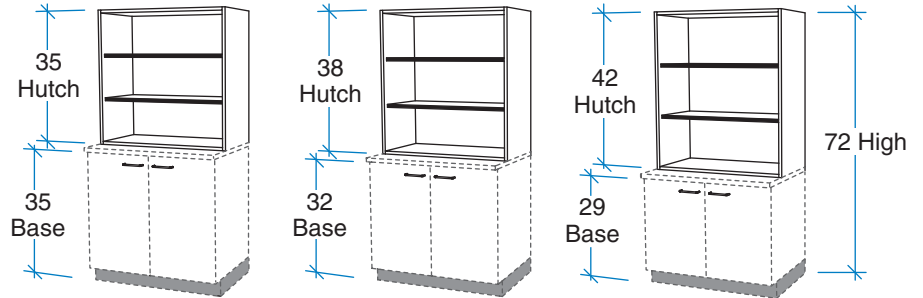

78 HIGH ASSEMBLY

Actual Height
77 13/16" (1977mm)

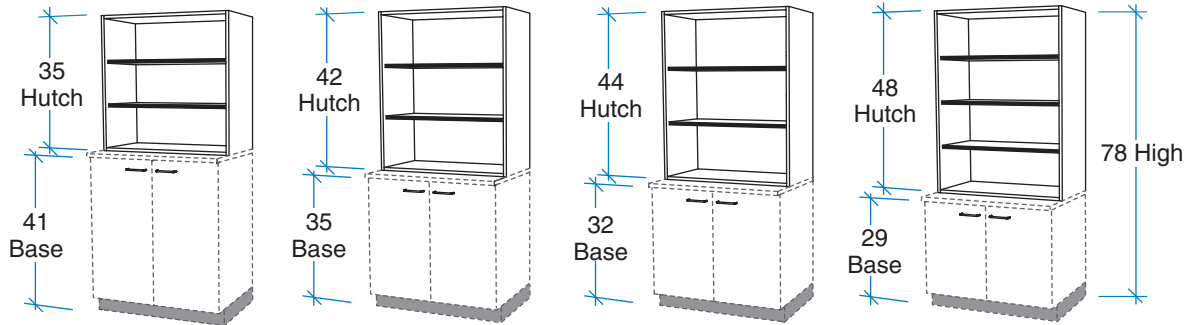

84 HIGH ASSEMBLY

Actual Height
84 1/8" (2137mm)

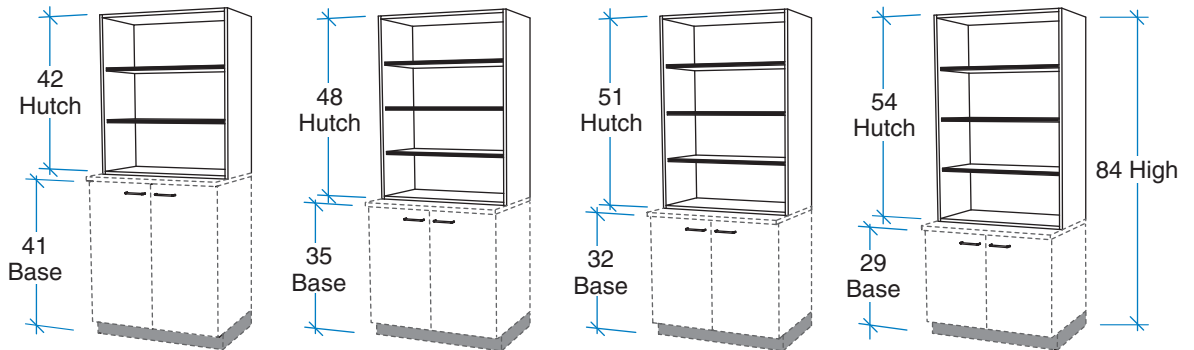

90 HIGH ASSEMBLY

Actual Height
90 7/16" (2297mm)

